

MANUAL

Envolve PVK

Pneumatic operated butterfly valve

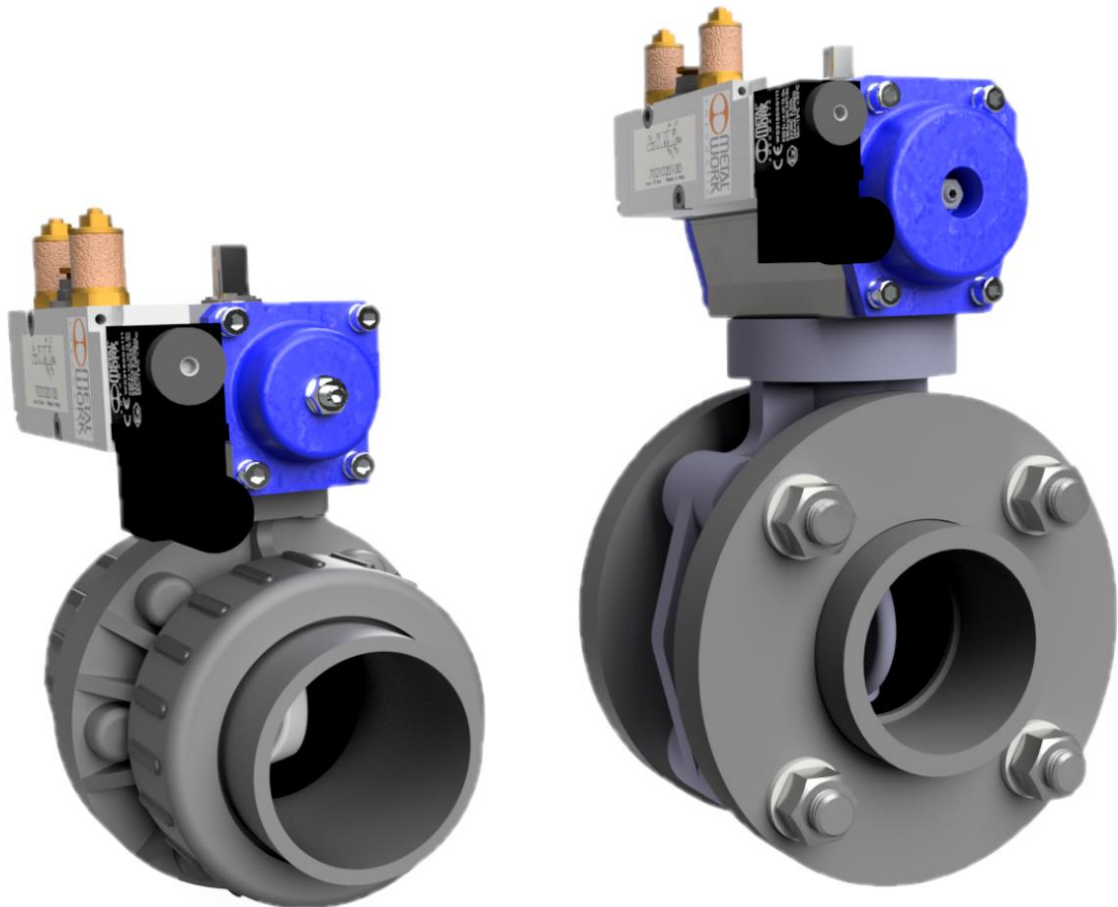

Version: 2024-07

PREFACE

This installation manual is a manual for the installer or technician who is installing the Envalve. It is not a manual for the end user of the Envalve.

If not entirely installed and connected, the Envalve has no real function and is therefore classified as a machine which cannot operate independently (or “unfinished machine”, later on this will be referred to as just “machine”).

The manual only contains prescriptions concerning the installation, the correct connection and safety-operation protocols regarding the Envalve PVK. It is not a manual for the entire installation in which the Envalve is installed. The installer should take care of that manual.

Every chapter has a number and chapters are divided into paragraphs where needed . The table of contents on page 3 provides an overview of the chapters and paragraphs with reference page numbers.

When a letter is stated between brackets this refers to the parts in Figure 1.

Within the scope of this user manual, whenever there is made reference to the “Envalve” , it is merely applicable to the Envalve series equipped with a pneumatic drive. For more information concerning the electrically operated Envalve series we kindly refer you to our website.

TABLE OF CONTENTS

Preface	2
Table of contents	3
1 Identification	4
1.1 General information	4
1.1.1 Description of the machine	4
1.1.2 Technical specifications.....	5
1.1.3 Schematic representation of the machine.....	6
1.2 Control and manual operation	7
1.3 Usage.....	7
1.4 Users.....	8
1.5 Media	8
1.6 Use environment	8
1.7 Warranty	8
1.8 CE and UKCA sign	8
2 Description.....	10
2.1 In general.....	10
2.2 Working principle	10
2.3 Transport and storage	10
3 Safety instructions	11
4 Installation	12
4.1 Mechanical.....	12
4.1.1 Tightening torque flanges	14
4.2 Electric	14
4.3 Pneumatic.....	14
5 Commissioning	15
6 Maintenance.....	15
7 Errors	15
8 Declaration of Conformity.....	16
9 UKCA Declaration of incorporation	17
Annexes.....	18
PKV series, actuator with electro-pneumatic control valve.....	19
CE declaration of conformity to components of the Envalve	20

1 IDENTIFICATION

This chapter contains some general information about the machine. The purpose of this chapter is to state the boundaries of the machine, the global functioning and possible applications of the machine. All Envalve PVK butterfly valves are equipped with a pneumatic drive.

1.1 General information

1.1.1 Description of the machine

The purpose and function of the Envalve is the regulation or stopping of a flow of fluid media through a pipe. The Envalve can be operated remotely. An Envalve consists of six main parts:

1. Drive; pneumatic (a)
2. Electro-pneumatic valve (b)
3. Silencers with control needle valves (c)
4. PVC Butterfly valve (d); incl. valve housing.
5. EPDM or Viton seal with pos. O-ring (e + pos. f).
6. Connection between the piping and the valve by means of:
Flange/collar or nut/ collar coupling (g and h).

In order to operate the valve, the outgoing axle is coupled to a pneumatic drive. This drive is rotated by means of compressed air. An electro-pneumatic valve supplies the drive with compressed air. If a voltage is put on the electro-pneumatic valve it will switch. The connecting supply voltage of the electro-pneumatic valve is 24 VAC, 24VDC or 230 VAC.

The electro-pneumatic valve is mono-stable, meaning that if the voltage over the valve is reduced to zero, it will return to its original position and the pneumatic drive will close the butterfly valve. The electro-pneumatic valve is equipped silencers with control needle valves. These control needles determine the speed with which the butterfly valve opens/closes. When using lubricants in the air circuit, pay attention to the fact that the lubricant is compatible with NBR. An extra option is a positional indicator which states whether the butterfly valve is open or closed.

The butterfly valves type NW 20 - 63 connect to the piping by means of swivel/collar coupling. The butterfly is seated in an EPDM seal (Viton seal optional) and an O-ring is placed between the collar and valve housing. The butterfly valves type NW 75 - 200 have a flange/collar connection to the piping. Their seal also functions as packing. The Envalve is prohibited from being used if it is not fully connected and installed in a suitable piping system with a maximum working pressure of 6 bar. The pressure drop over the Envalve must not exceed 6 bar.

1.1.2 Technical specifications

Type	VK-G PVK
Amount of butterfly valves	1
Power (control valve coil)	5 – 9 W
Voltage	24 Vac / 24Vac / 230Vac
Control valve pressure	See Table 3
Working pressure Valve actuator	Max. 6 bar
Glue connection	20 - 63
Valve capacity (Kvs value)	550 - 1233 L/hour / valve
Pneumatic drive actuator	Pneumatic actuator Alphair series AP i.c.w. electric-pneumatic mono stable valve type 5/2-1/4"

Table 1: Specifications PVK series 20 - 63, pneumatic actuator + electro-pneumatic valve

Type	VK-F PVK
Amount of butterfly valves	1
Power (control valve coil)	5 – 9 W
Voltage	24 Vac / 24Vac / 230Vac
Control valve pressure	See Table 3
Working pressure Valve actuator	Max. 6 bar
Glue connection	75 – 200
Valve capacity (Kvs value)	1700 - 30500 L/hour / valve
Pneumatic drive actuator	Pneumatic actuator Alphair series AP i.c.w. electric-pneumatic mono stable valve type 5/2-1/4"

Table 2: Specifications PVK series 75 - 200, pneumatic actuator + electro-pneumatic valve

Type	Minimum needed Air pressure [Bar]
PVK 20	3,6
PVK 25	3,6
PVK 32	3,6
PVK 40	4,8
PVK 50	4,7
PVK 63	5,0
PVK 75	3,3
PVK 90	2,8
PVK 110	2,9
PVK 125	2,7
PVK 160	4,1
PVK 200	3,9

Table 3: Minimum needed air pressure per valve

1.1.3 Schematic representation of the machine

Sketch containing the names and reference letters of the most important parts.

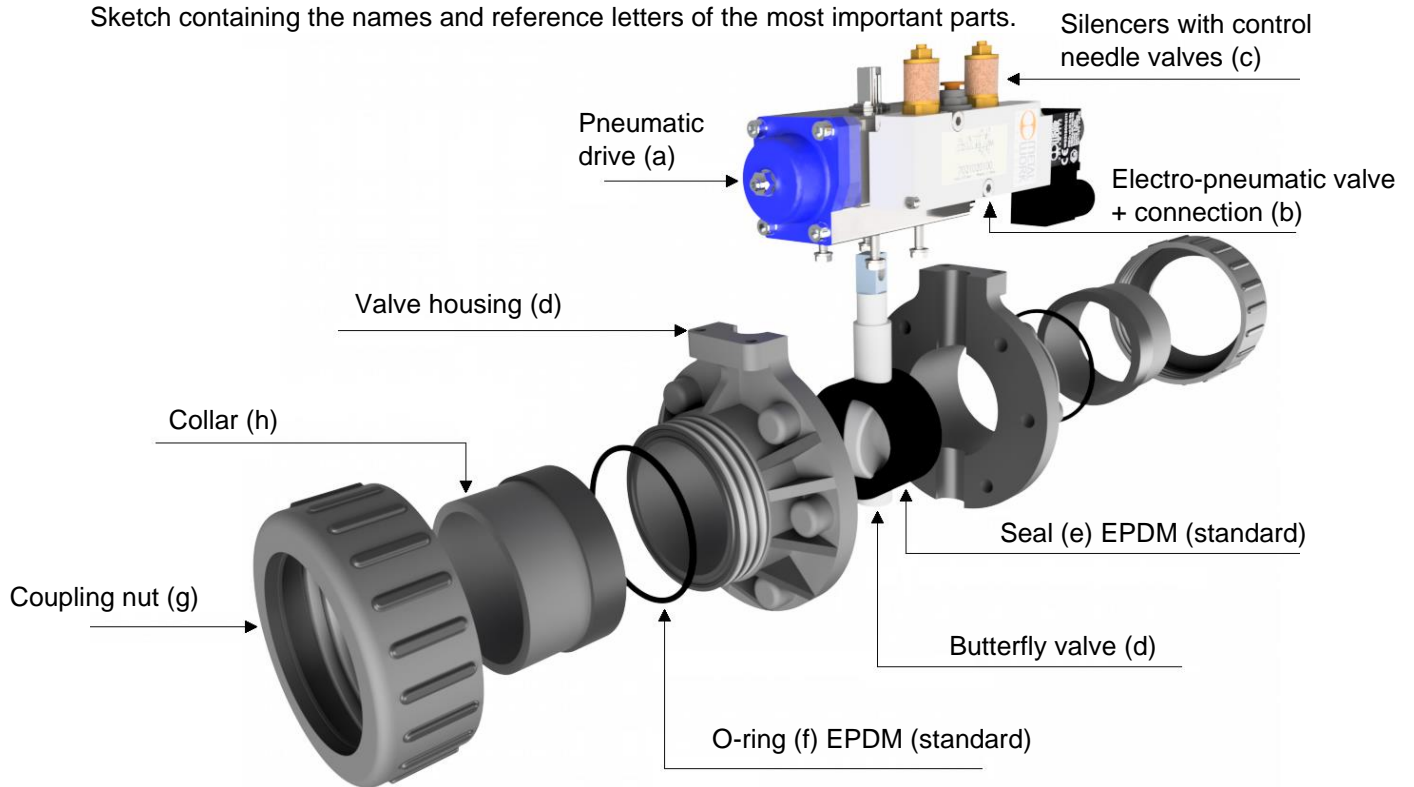

Figure 1: Schematic representation of an Envalve glue size 20-63

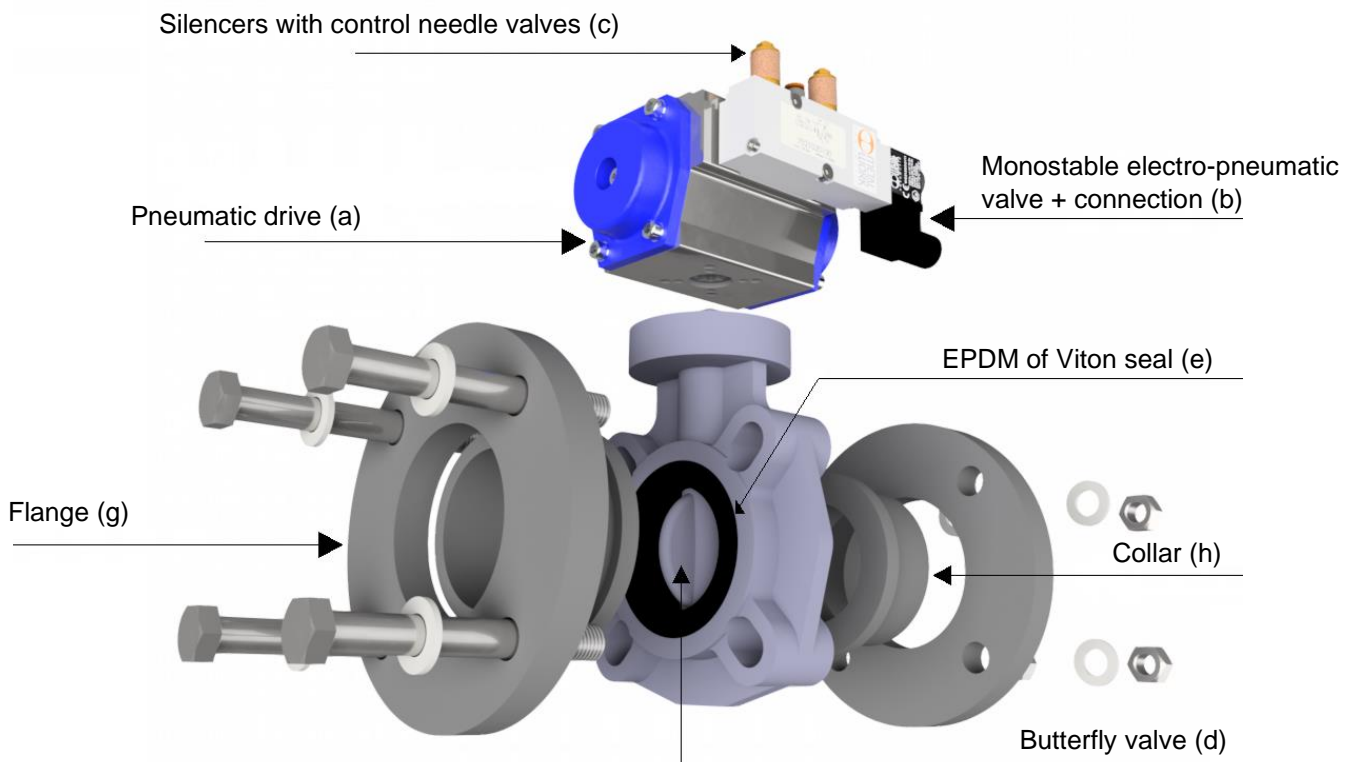

Figure 2: Schematic representation of an Envalve glue size 75-200

1.2 Control and manual operation

The Envalve can be remotely operated, by means of the electro-pneumatic valve. This valve is connected to the pneumatic drive. There are two possibilities when the Envalve needs to be manually adjusted. Figure 3 illustrates these possibilities.

1. Under preservation of air pressure, the set screw of the electro-pneumatic valve can be rotated from the "0-position" to the "1-position" by a flat screw driver. If air pressure is maintained, this will cause the butterfly valve to open or close, depending on the valves configuration. (left option in Figure 3)

Important! After using the set screw of the electro-pneumatic valve, return it to the 0-position. In this position the valve is voltage-free

2. If there is no air pressure, the butterfly valve can be manually rotated by means of a wrench. Place the wrench on the outgoing axle of the pneumatic drive and rotate the shaft to its desired position. In order to prevent harm to the machine and its operator, the air intake , connection (3) in Figure 8, needs to be removed. This prevents air from returning to the control valve and the actuator.

Important! The air pressure is not allowed to return to the electro-pneumatic valve during this operation. Uncouple the air intake before manually adjusting the valve!

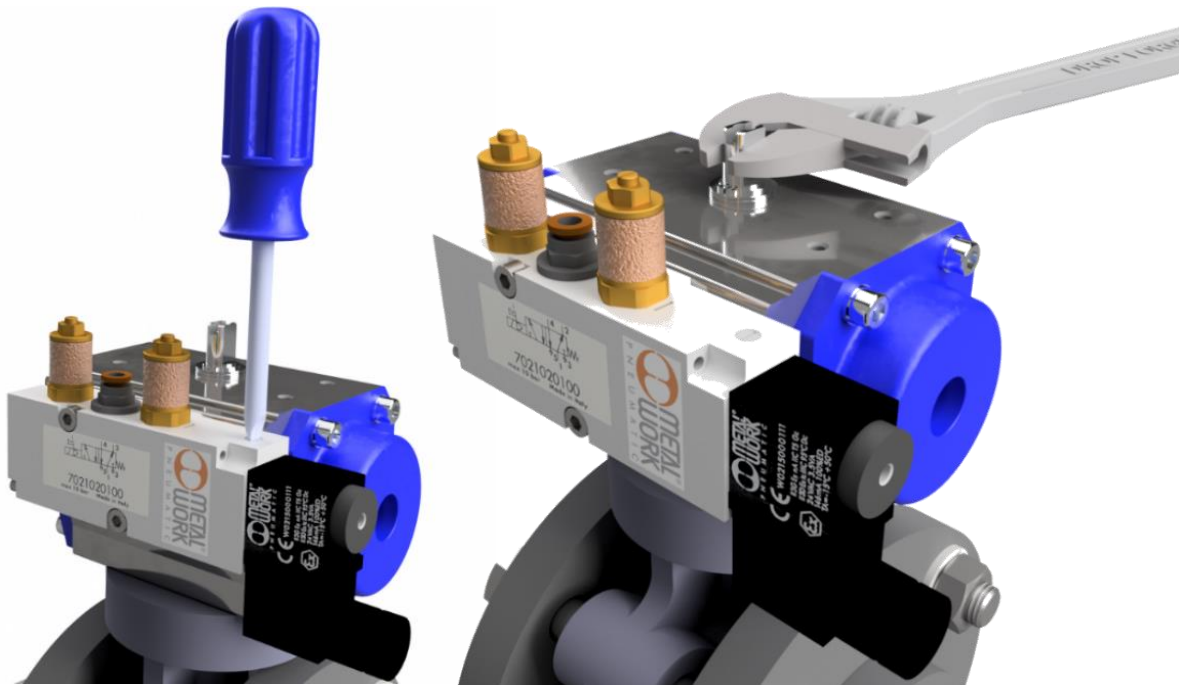

Figure 3: Manual adjustment Envalve

For more information pertaining to the remote control of the Envalve, please regard paragraph 4.2. This paragraph references the electrical scheme with which the correct connection can be made. Further connections to e.g. a wiring cabinet or a frequency driver are outside the demarcation of this manual

1.3 Usage

The Envalve is intended to be used for closing off the flow of a liquid medium. The Envalve is only allowed to be used in a suitable piping system. The Envalve cannot be used for matters that have not been defined within the scope of usage or when an operation-failure can cause a potentially hazardous environment.

1.4 Users

In general, there are no direct 'users' of the Envalve, because it is operated remotely by a control panel or other (semi)automatic controller. Authorized users are at least 18 years and employed at the company at which the Envalve is installed, and who are designated by their employee to be competent and able to operate the Envalve.

Unauthorized users are users who do not comply with above description. Unauthorized users are users who cause danger and/or unsafe situations to themselves and/or others while using the Envalve.

1.5 Media

The Envalve is not chemically resistant to all chemicals, ask the producer of the Envalve for advice when in doubt. If a chemically incompatible medium is used i.c.w. the Envalve, leaking will occur and warranty will expire.

It is possible to alter the seals in the Envalve in order to make it more resilient to other chemicals, ask VDEG for advice.

1.6 Use environment

The Envalve is meant to be used as a controlled stop of a flow of fluid media. The Envalve may only be used when it is fully installed and connected according to the installation procedures.

The Envalve and particularly the drive may not be submerged.

The Envalve can be installed in virtually every position, except upside down (pneumatic drive under the valve), see also paragraph 4.1.

The Envalve cannot be used in an explosive environment.

1.7 Warranty

The warranty is 6 months from commissioning, with a maximum term of 2 years after production. Commissioning is the installation date of an Envalve in an installation. Parts must be brought to the producer when warranty is claimed.

Warranty expires with one or more of the following terms:

- unprofessional use and/or installation;
- repeatedly ignoring advice from producer and/or supplier;
- reparation, maintenance or use by incompetent or unauthorized persons;
- use of incorrect electrical or fluid connections;
- use of the machine in an unsuited environment;
- intended damaging or modification of the machine.

All these and further warranty terms are in conformation with the METAALUNIEVOORWAARDEN.

1.8 CE and UKCA sign

The CE and UKCA sign concerns the conformity of the Envalve with the directives as mentioned on the declaration. Because it is an unfinished machine, the Envalve cannot comply with all the essential safety precautions, a list of these can be supplied by the producer.

The CE and UKCA signs are located on the sticker on the base plate.

According to the low voltage directive, the Envalve is classified as a Class I machine.

1.9 Rest risks

For practical and economic reasons it is impossible to fully cover all the risks for 100%, besides, the risk of a machine is tightly correlated with the functionality of the installation as a whole. These so called rest risks are listed in the table below. It is important that the user is aware of the fact, even while we have taken all possible safety precautions, the use of the Envalve involves certain risks. Follow the prescriptions in this manual in order to minimize these risks.

Risk-Nr.	Rest risk description	Risk-factor ¹	Class
1.	When the Envalve is used while it is not fully installed and connected, there is a danger of fingers getting stuck.	3	A
2.	Risk on fire, if the electrics are not professionally connected, a risk on short circuit and fire arises.	4	A

Table 4: List of rest risks

¹ The aim is to reduce every risk to a level below 4, but this isn't always possible due to the functionality of the machine.

2 DESCRIPTION

In this chapter the machine is described, it is the background information needed to work safely with the machine.

2.1 In general

The Envalve must be installed in a suitable piping system. The pneumatic connections can be made once the installation is completely finished. With an Envalve, a flow of fluid media through a pipe, can be shut of remotely.

Standard, for the pneumatically driven butterfly valve is an open c.q. closed control system. Another possibility is to make the butterfly valve's control system positional. This requires a special bi-stable electro-pneumatic valve. Another option is to install a position indicator, which enables positional feedback. This option lies outside the scope of this manual, inquiries regarding this matter can be posed to the VDEG technical sales team.

The pneumatically actuated butterfly valve uses mono-stable electro-pneumatic valves. In its standard configuration, the butterfly valve closes when the supply voltage is removed and the air pressure in the control valve is maintained at 6 bar. By disassembling the control valve from the pneumatic drive and thereafter mounting it 180 degrees rotated, one is able to reverse the working principle of the butterfly valve. Without a supply voltage, the butterfly valve will now rotate to an open position, as long as air pressure is maintained. This function is illustrated in figure 4.

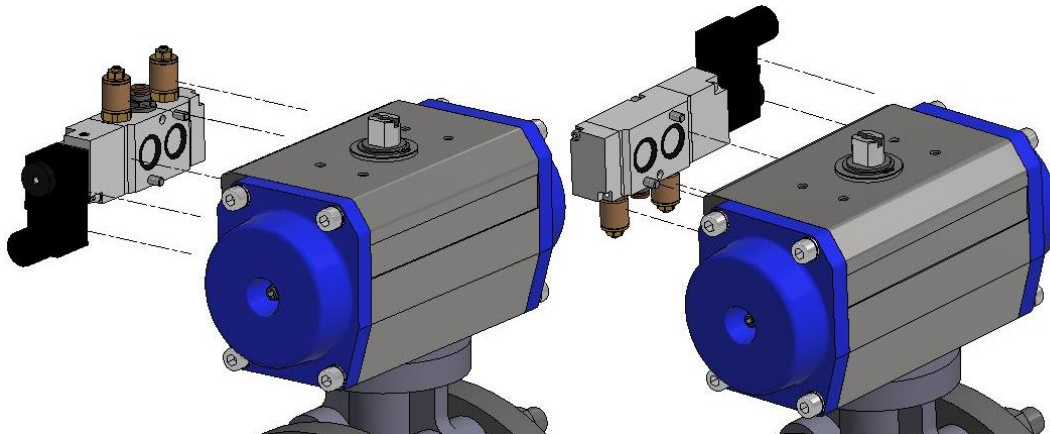

Figure 4: Configuration electro-pneumatic valve

The coupling between the Envalve and the piping consist of a nut/collar connection up till glue size 63 mm. Envalves with a greater glue size require a flanged connection using nuts and bolts. Different collars are used in these situation. (see 4.1).

With a glue sizes greater than 75 mm, the valves seal is also the butterfly shaft packing. According to standard model specifications this seal is made of EPDM, but upon request, it can also be made out of Viton. Envalves with smaller glue sizes (20 -63 mm) require an O-ring (standard EPDM) between the collar and valve housing.

2.2 Working principle

The Envalve is a remotely operated butterfly valve. Its functionality lies in the fact that an actuator can rotate the butterfly, hereby restricting the flow area of a pipe.





2.3 Transport and storage

The Envalve does not require packaging for transport and storage. The Envalve can be put down in a stable manner, but they are not allowed to be put on top of one another, without special provisions. The Envalve and especially the drive is splash proof and needs to be protected from rain.

3 SAFETY INSTRUCTIONS

The following safety instructions must be observed at all times when working with the Envalve PVK.

- The Envalve should not be connected to compressed air and/or electricity until it is built into a suitable system. Before removing the Envalve, the compressed air and/or electrical connection must be disconnected/removed.
- During maintenance and/or repair work, the electricity and possibly compressed air must always be shut off first. To shut off the electricity, the isolating switch of the controlling device (control cabinet) must be used, so it must be locked. After the work, always connect everything completely again and test it.
- Work or connection of the electrical part of the Envalve may only be carried out by qualified personnel.
- Connect the earth wire to the terminal box with the following sign 
- Make sure that the power supply is connected to an earthed terminal circuit that is fused at a maximum of 16 A with a 30 mA earth leakage circuit breaker (230 VAC version).

Safety symbol	Description
	Automatic starting machine!
	Electric voltage present!
	Rotating parts!
	Remove power plug before working on the system!
	Reading manual obligated!

4 INSTALLATION

This chapter describes the installation of the Envalve. The butterfly valve needs to be mounted voltage-free to the installation.

4.1 Mechanical

For the correct installation of the Envalve, first fit all the piping without glue. When everything is correct in size and properly aligned, loosen the bolts or the nut and take the actual valve from between the collars. Be careful not to damage the seal while doing this. Put the valve aside and remove the collars from the piping.

Glue the collars to the piping. Excess glue on the inside of the piping should be removed, this glue can get between the seal and the paddle and cause serious damage or leaking.

Make sure you put the flanges or the coupling over the piping behind the collars before the collars are glued, the flanges or coupling cannot be added later!

From NW75 and larger there is only one seal, serving as seal between the paddle and housing and as seal between the collars and actual valve. NW63 and smaller have two separate O-rings as seal between collar and valve and another seal between the housing and the paddle.

It is important that for all the Envalve's plain smooth collars are used, not the ones with a groove (for an O-ring), otherwise they will leak. The use of additional seals is unnecessary and we strongly advise not to.

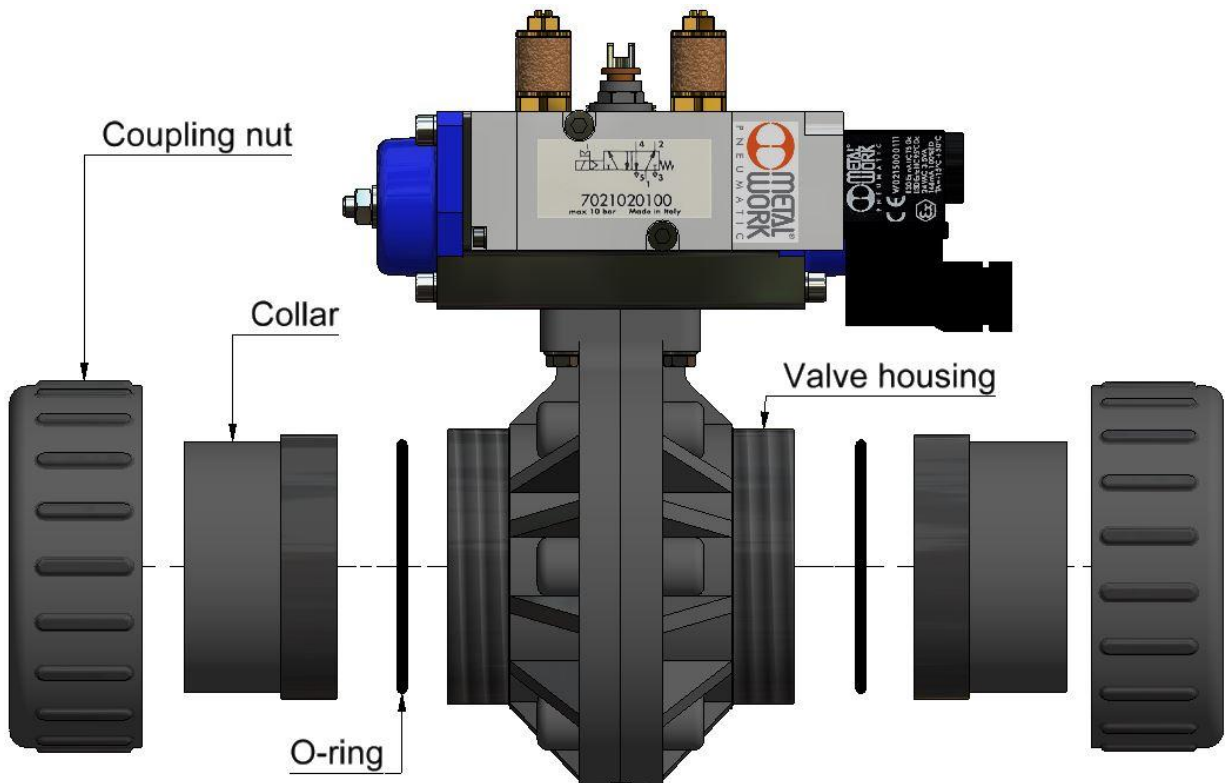

Figure 5: Sealing Envalve with glue size 20 - 63 mm

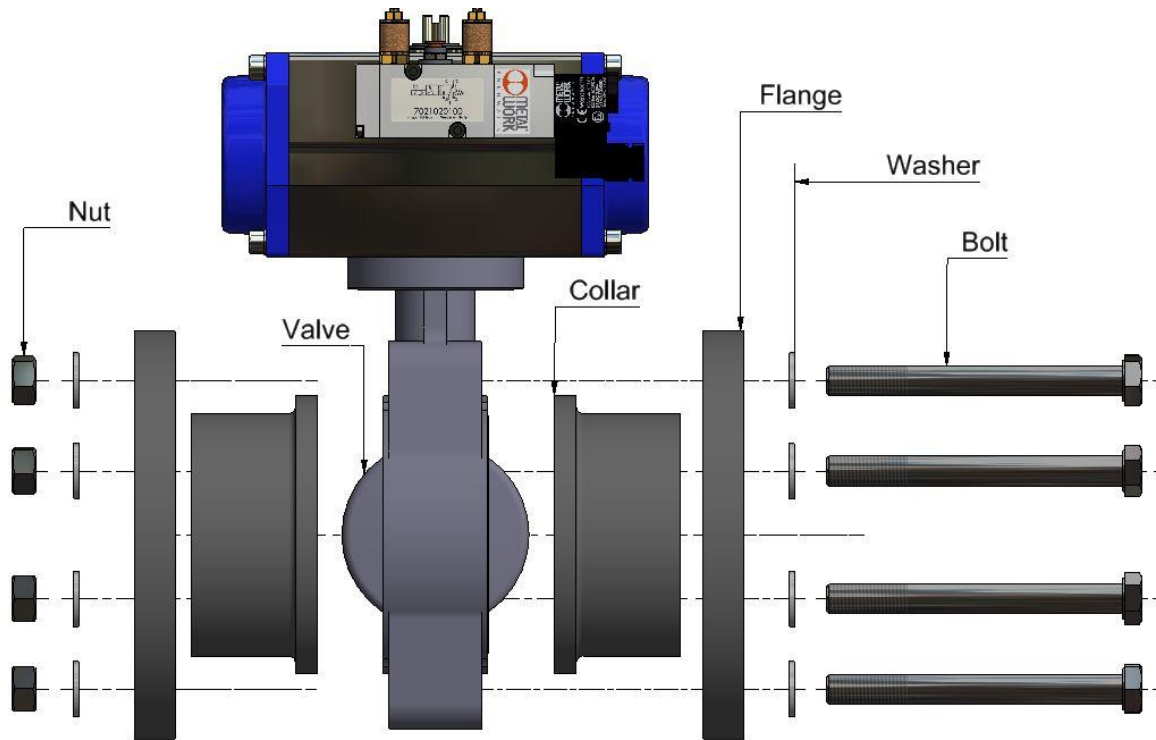

Figure 6: Sealing Envalve with glue size 75 – 200 mm

When the collars have been glued, the butterfly valve can be placed in between them, mind that the seals are not damaged in this process. The butterfly valve can be mounted in every position except upside down. See Figure 7.

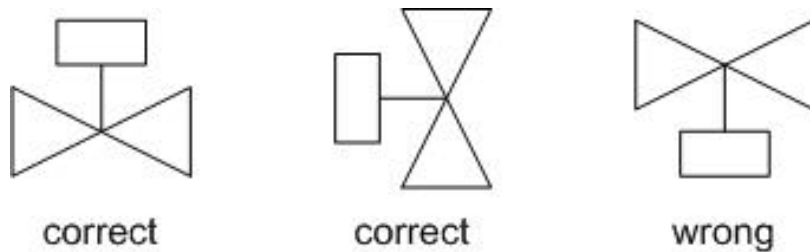

Figure 7: Mounting configurations Envalve

When the valve is positioned correctly between the collars the flanges can be shoved over the collars and secured with the metal bolts and nuts (NW75 and larger) or the coupling nut can be tightened (NW63 and smaller).

After installation the connection must be checked; try to operate the valves manually by closing and opening them following the correct procedures. This must be possible without scraping noise and with moderate force. See paragraph 1.3 for instructions on manual operating.

4.1.1 Tightening torque flanges

It is important that the bolts and nuts are not over-tightened causing the cuff to deform. When the bolts are tightened too tightly, this can cause the valve to block. See the table below for tightening torques.

NW	DN	Torque
75	65	15 Nm
90	80	18 Nm
110	100	20 Nm
125	125	35 Nm
160	150	40 Nm
200	200	55 Nm

Table 5 Tightening torque VK NW 75 - 200

4.2 Electric

The valves must be electrically connected by professional and competent individuals, please regard the wiring schemes in the annexes for help.

- Remove the screw on top of the cap of the (electric) control valve (the black part);
- remove the cap of the coil of the control valve;
- put the power cable trough the cable gland;
- connect the earth cable to the terminal marked with the earth sign (only the 230 V version);
- connect the wires to terminal 1 and 2;
- tighten the cable gland;
- place the seal between the coil and the cap;
- put the cap back on the coil and tighten the screw;
- check the functioning of the Envalve.

4.3 Pneumatic

The pneumatic connection of the Envalve should be carried out according to the following steps. For further details of the control valve, see the appendix;

- Check that the available air pressure is sufficient to open the valve. See **Fout! Verwijzingsbron niet gevonden.** on page **Fout! Bladwijzer niet gedefinieerd.**;
- Connect pressurized air to terminal 3 according to **Fout! Verwijzingsbron niet gevonden.**;
- Check that the connection of the pressurized air is tight;
- Check the operation of the valve.

5 COMMISSIONING

Connect the Envalve electrically and pneumatically according to the steps described in sections 4.2 and 4.3 respectively, Check that the valve is fitted correctly and the flanges are tightened according to the maximum torque (see Table 5).

Before filling the system with liquid, check whether the air pressure present is opening and closing the valve and the further operation of the butterfly valve (automatic or manual).

6 MAINTENANCE

The valve and actuator are maintenance-free when used within the area for which they are designed. Routine maintenance and monitoring is desirable. Servicing the Envalve PVK involves the following:

- Visual inspection of correct opening and closing of the valve;
- Visual inspection of all pneumatic and electrical connections to ensure that they are still sufficiently tight;
- Clean the installation with a dry cloth. If necessary, a damp cloth **without** touching the electrical part. Never use aggressive (cleaning) fluids.
- When the installation is disassembled, make sure that there is no power and the air pressure supply is shut off to the Envalve to prevent unwanted movement of the valve.

7 ERRORS

Error	Cause	Solution
Valve does not turn	No power supply present	Find the problem and fix the power supply.
	Incorrect or wrong connection	Check the connections (schematics in the annex)
	Short circuit due to moist	Find the cause, try to dry the drive, replace the seal of the drive if needed
	Blown fuse	Check the connection, find the cause, and if necessary replace the fuse.
	Burned coil	Find the cause and replace the coil, check the supply voltage and functioning of the valves.
	Air pressure to low	Make sure that the supply of air pressure is sufficient enough following Table 3
Drive turns instable/restless, meaning: back and forth, or closes/open partially	Too much voltage drop due to long cables or insufficient diameter	Measure the voltage at the control valve, calculate the required cable length and voltage drop. Replace the cable if necessary.
	Fluctuations in power supply	Check the power supply cable
	Too little air pressure	Increase the air-pressure
Drive fails regularly	Loose contact in power supply	First, make sure the power is switched off! Check and tighten all contacts.
Drive does not turn (entirely) to the end position	Pneumatic drive is defect	Replace the driver, it often means it takes too much torque to turn the butterfly valve.
	The system pressure or pressure drop over the valve is too high	Check the system pressure and adjust accordingly.
	Solids obstruct the valve	Disassemble the product and remove any obstructions.

Table 6 Errors and corresponding solutions

8 DECLARATION OF CONFORMITY

EG-Declaration of CONFORMITY

(In accordance with Annex IIA of the Machinery Directive 2006/42/EC)

We,
Van der Ende Pompen
Aartsdijkweg 23
2676 LE Maasdijk
Netherland

declare, under our sole responsibility, that the following machine

Envalve
Series PVK

to which this declaration relates, is intended be built into a machine or combined with other machines,
to form one machine which is applicable to the following directives;

Machinery Directive	2006/42/EC
Low Voltage Directive	2006/95/EC
EMC Directive	2004/108/EC

The product this declaration refers to must not be put into service until the machinery into which it is to be incorporated has been declared in conformity with the provisions of the relevant European Directives.

Nederland
Maasdijk
20 januari 2020

L. van der Ende



9 UKCA DECLARATION OF INCORPERATION

UKCA-Declaration of incorporation

We, Van der Ende Pompen
Aartsdijkweg 23
2676 LE Maasdijk
Netherland

declare, under our sole responsibility, that the following machine

Envalve
Series PVK

to which this declaration relates, is intended be built into a machine or combined with other machines, to form one machine which is applicable to the following directives and their admendments;

Supply of Machinery (Safety) Regulations	2008:1597
Electrical Equipment (Safety) Regulations	2016:1101
Electro Magnetic Compatibility Regulations	2016:1091

The product this declaration refers to must not be put into service until the machinery into which it is to be incorporated has been declared in conformity with the provisions of the relevant UKCA regulations.

Nederland
Maasdijk
13 December 2022

L. van der Ende



ANNEXES

- PVK Series actuator with electro-pneumatic control valve
- CE declaration of conformity to components of the Envalve

PKV series, actuator with electro-pneumatic control valve

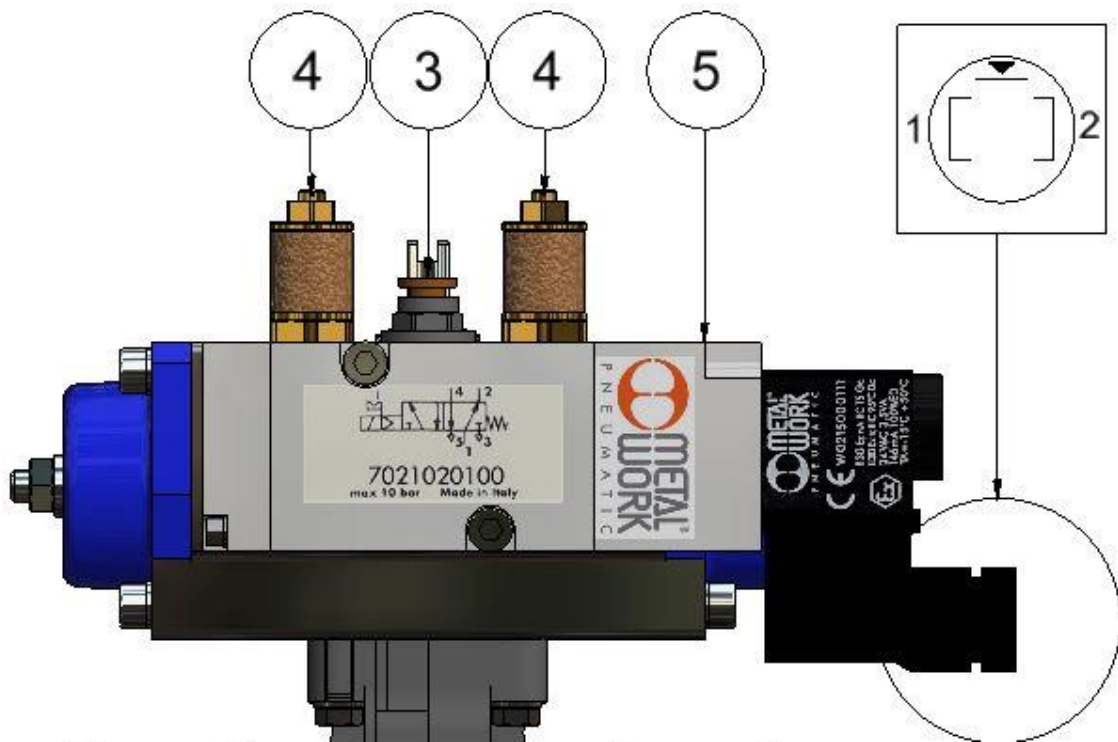

Figure 8: Electrical scheme of electro-pneumatic control valve PVK series

Figure 8 shows a schematic representation of the connecting socket fuse.

The flat plug (marked with a small earth sign) is the earth connection, by applying a potential over connection 1 and 2, the control valve is actuated and the Envalve will open. The control valve is monostable, so the control valve will close automatically when the steering current is removed and the Envalve will return to its default position.

Connection (3) is for the pressurized air supply.

Note. Use with clean compressed air without oil lubrication (valve and actuator are lubricated for the service life). When oil lubrication is applied in the compressed air, it must be checked whether the oil goes well with the NBR seal and does not affect it.

The connections to the pneumatic drive, are shown in Figure 4 in chapter 2.1. These can be reversed in order to reverse the working principle of the Envalve. Connections (4) are the silencers equipped with control needle screw valves. Users/installers do not have to change these connections unless they want to adjust in order to regulate the speed with which the valve opens/closes or to prevent water hammer.

Connection (5) is a set screw by which the valve can be manually opened/closed. This has to be done under preservation of air pressure. For the correct procedure we kindly refer you to chapter 1.2.

CE declaration of conformity to components of the Envalve

DNV·GL

MANAGEMENT SYSTEM CERTIFICATE

Certificato no./Certificate No.:
CERT-06679-2000-AQ-MIL-SINCERT

Data prima emissione/Initial date:
05 giugno 2015

Validità:/Valid:
13 giugno 2018 - 13 giugno 2021

Si certifica che il sistema di gestione di/This is to certify that the management system of

ALPHA POMPE S.p.A.
Via Molino Emili, 16 - 25030 Maclodio (BS) - Italy

È conforme ai requisiti della norma per il Sistema di Gestione Qualità/
has been found to conform to the Quality Management System standard:
ISO 9001:2015

Questa certificazione è valida
per il seguente campo applicativo:

**Progettazione, produzione e vendita di
attuatori pneumatici rotanti e valvole ad
azionamento pneumatico
(EA: 18)**

This certificate is valid
for the following scope:

**Design, manufacture and sale of pneumatic
rotary actuators and pneumatic operated
valves
(EA: 18)**

Luogo e Data/Place and date:
Vimercate (MB), 24 maggio 2018



0003 01 0003 01
0004 01 0003 01
0005 01 0003 01
0006 01 0003 01

0007 01 0003 01
0008 01 0003 01
0009 01 0003 01
0010 01 0003 01

0011 01 0003 01
0012 01 0003 01
0013 01 0003 01
0014 01 0003 01

Per l'Organismo di Certificazione/
For the Certification Body
DNV GL - Business Assurance
Via Energy Park, 14 - 20871 Vimercate
(MB) - Italy

Zeno Beltrami
Management Representative

Products Conformity Declaration

The Company

METAL WORK S.p.A.
Via Segni 5 - 25062 Concesio (BS) - ITALY

declares under its own responsibility that the following products:

- VALVES
- ELECTROVALVES
- FIELD BUS SYSTEMS

to which this declaration refers has been manufactured in its plant in Italy.
Metal Work S.p.A. has a Quality Management System certified by the German Committee
DEKRA Certification S.r.l. according to the norm ISO 9001:2015

The registration number is 71295532/8-A1 and it is valid till 18-12-2022.
(Copy of the certificate and product technical information are enclosed.)

This component cannot be mounted on a machine unless the same complies with the main requirements
prescribed by Directive 2006/42/EC.

Concesio, January 2020

Quality Assurance Manager



Eng. Giorgio Mazzoni



Aartsdijkweg 23, 2676 LE Maasdijk, The Netherlands
+31 174 51 50 50 · info@vanderendegroup.com · www.vanderendegroup.com