

1DW Series

SUBMERSIBLE DEWATERING SUMP PUMP



The 1DW Series is a stainless-steel dewatering sump pump that handles virtually any solids that moves through its screened inlet. The durable bottom suction design is ideal for applications from which large volumes of water need to be removed. Easily transportable, it can be used on construction sites or in flooded areas to effectively remove unwanted fluid. This "Complete. Reliable. Blue." pump is ideal for draining ditches, pits, and industrial water drainage or transfer.

APPLICATIONS

- Residential
- Light commercial
- Industrial
- Draining ditches and pits
- water drainage/transfer
- Water transfer
- Excavating drainage in building trade

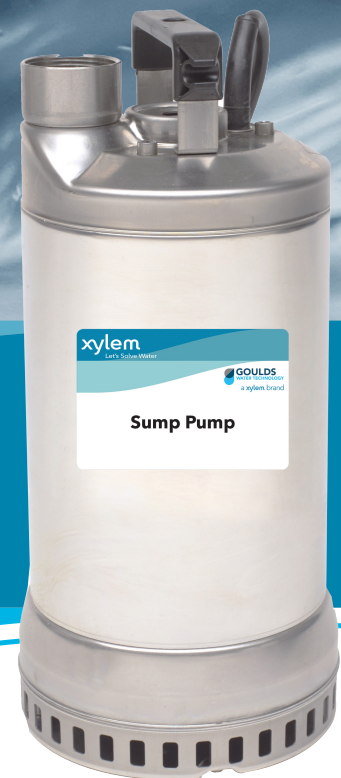

FEATURES

- AISI 304 SS open impeller
- AISI 304 SS diffuser plate with a polyurethane coating for maximum resistance to abrasion
- Mechanical seal with silicon carbide sealing faces, AISI type 300 stainless steel components running in a protected oil chamber, and BUNA-N elastomers
- AISI type 304 stainless steel, high strength pump shaft with keyed and locking cap screw impeller fastening
- Air-filled class F insulated motor, designed for continuous operation
- Pump with ratings within the motor's working limits that can be operated continuously without damage
- Upper and lower heavy-duty ball bearing construction
- 3 Year standard warranty (4 Years GPDA)

DIMENSIONS

(All dimensions are in inches. Do not use for construction purposes.)

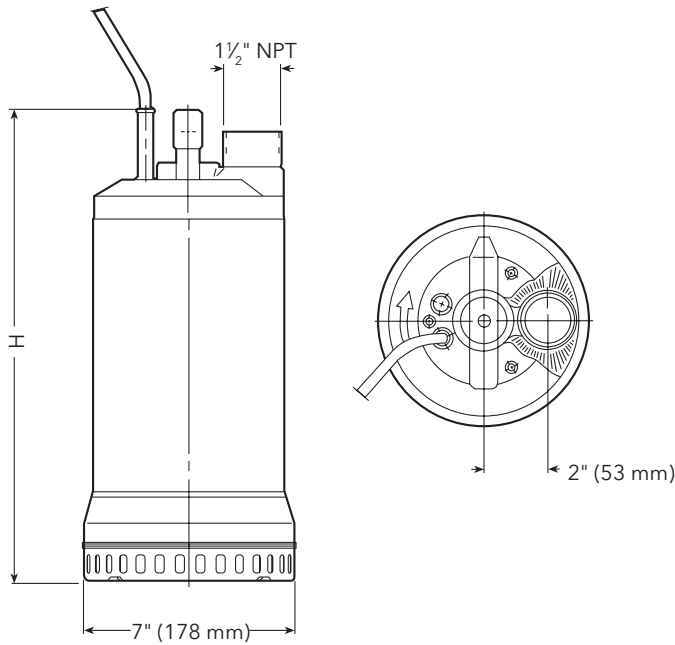

Series	HP	Phase	Dimensions in inches (mm)	Discharge Size
			H	
1DW	1/2	1	14 7/8 (363)	1 1/2"
		3	13 5/8 (348)	
	3/4	1	15 1/8 (383)	
		3	14 7/8 (363)	
	1	1	15 7/8 (403)	
		3	15 1/8 (383)	
1 1/2	3	15 7/8 (403)		

MATERIALS OF CONSTRUCTION

Component	Material
Pump body and motor casing	Stainless steel (AISI 304)
Outer sleeve	Stainless steel (AISI 304)
Impeller	Stainless steel (AISI 304)
Motor shaft	Stainless steel (AISI 304)
Suction strainer	Stainless steel (AISI 304)
Front diffuser plate	Stainless steel (AISI 304) coated with polyurethane elastomer
Lower mechanical seal	Silicon carbide/silicon carbide
Upper lip seal	Nitrile rubber
Handle	Stainless steel (AISI 304) coated with polyacetalic resin



Xylem Inc.
 2881 East Bayard Street Ext., Suite A
 Seneca Falls, NY 13148
 Phone: (866) 325-4210 • Fax: (888) 322-5877
www.xylem.com/goulds

Xylem is a registered trademark of Xylem Inc. or one of its subsidiaries. Goulds is a registered trademark of ITT Manufacturing Enterprises LLC and is used under license. All other trademarks or registered trademarks are property of their respective owners.

© 2024 Xylem Inc. GWT1DW-SS-120078 R1 May 2024

PERFORMANCE CURVES

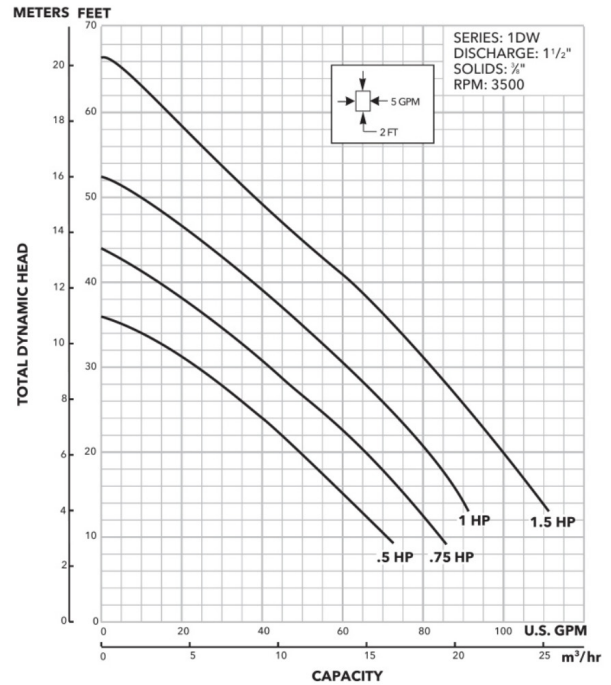

MECHANICAL DATA

Order Number	HP	Volts	Phase	Maximum Amps	RPM	Weight (Lbs.)	
1DW51C0EA	1/2	115	1	10.3	3450	29	
1DW51C1EA		230		4.5			
1DW51C3EA		3	460	2.5		27	
1DW51C4EA	1.3						
1DW51D1EA	3/4	230	1	5.7		3450	32
1DW51D3EA				3.6			
1DW51D4EA		3	460	1.8	29		
1DW51E1EA	1			230			6.3
1DW51E3EA		4.0					
1DW51E4EA	3	460	2.0	33			
1DW51F3EA			1 1/2		230	5.6	37
1DW51F4EA	2.7						

AGENCY LISTINGS (Three phase only)



Tested to UL 778 and CSA
 22.2 108 Standards
 By Canadian Standards
 Association
 File #LR38549

Learn more about
 1DW Series Pumps



COMPLETE. RELIABLE. BLUE.

Learn more about
 our complete line
 of wastewater
 products.

